

# MASABA

VERMILLION, SD USA 605-624-9555

**SUBMITTED FOR CUSTOMER APPROVAL**

APPROVED  REVISE  REJECTED

APPROVED BY: \_\_\_\_\_

APPROVAL DATE: \_\_\_\_\_

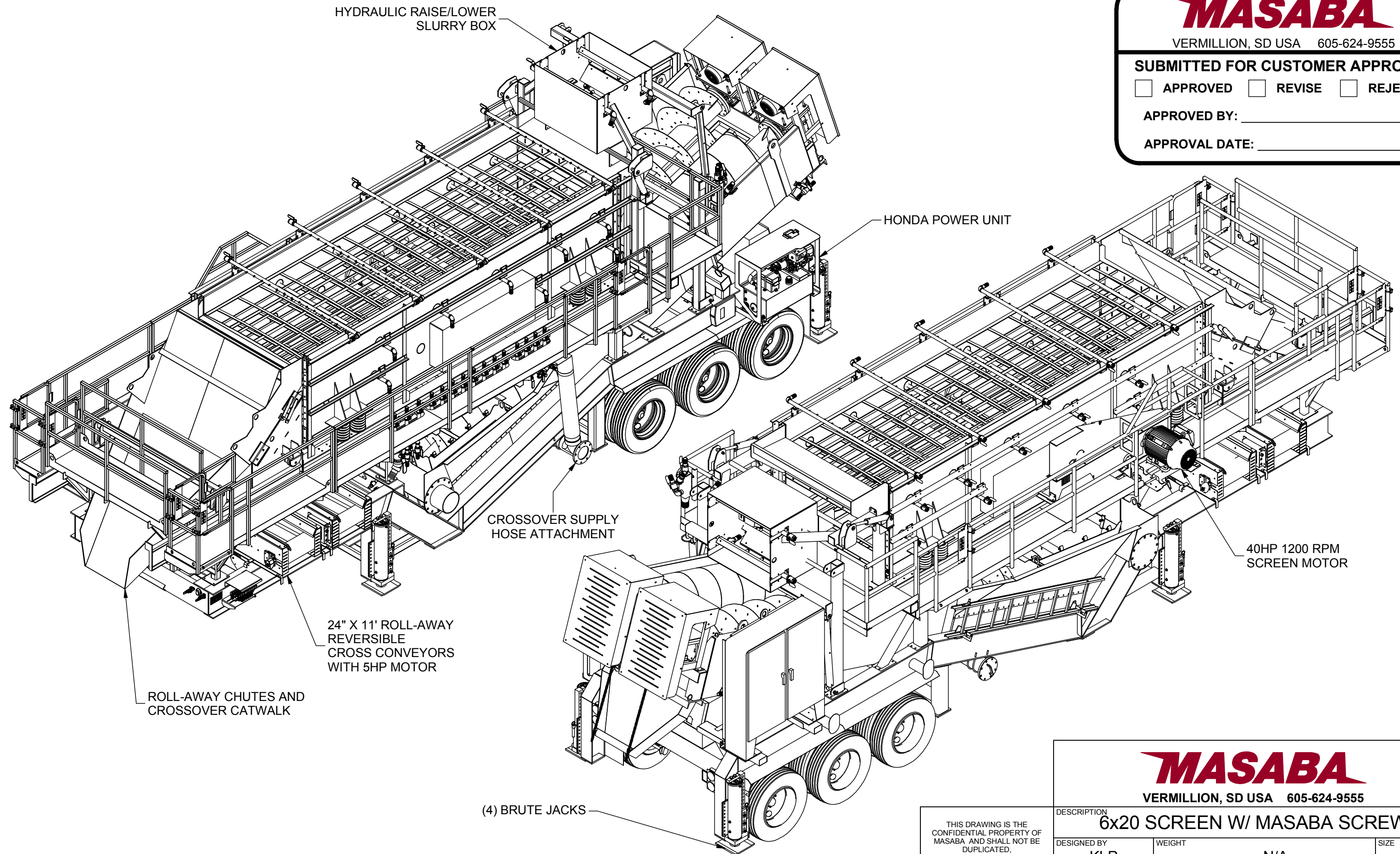

# MASABA

VERMILLION, SD USA 605-624-9555

DESCRIPTION  
**6x20 SCREEN W/ MASABA SCREW**

DESIGNED BY <b>KLP</b>	WEIGHT N/A	SIZE <b>B</b>
DRAWN BY <b>KLP</b>	DATE 12/5/2017	SHEET 1 / 4
SCALE 1/4" = 1'	PART NUMBER 18149000	REV 000

THIS DRAWING IS THE CONFIDENTIAL PROPERTY OF MASABA AND SHALL NOT BE DUPLICATED, COPIED, REPRODUCED OR DISCLOSED WITHOUT AUTHORIZED PERMISSION FROM MASABA. THIS DOCUMENT IS TO BE RETURNED UPON REQUEST.

000			KLP
REV	DESCRIPTION	DATE	APPRVD

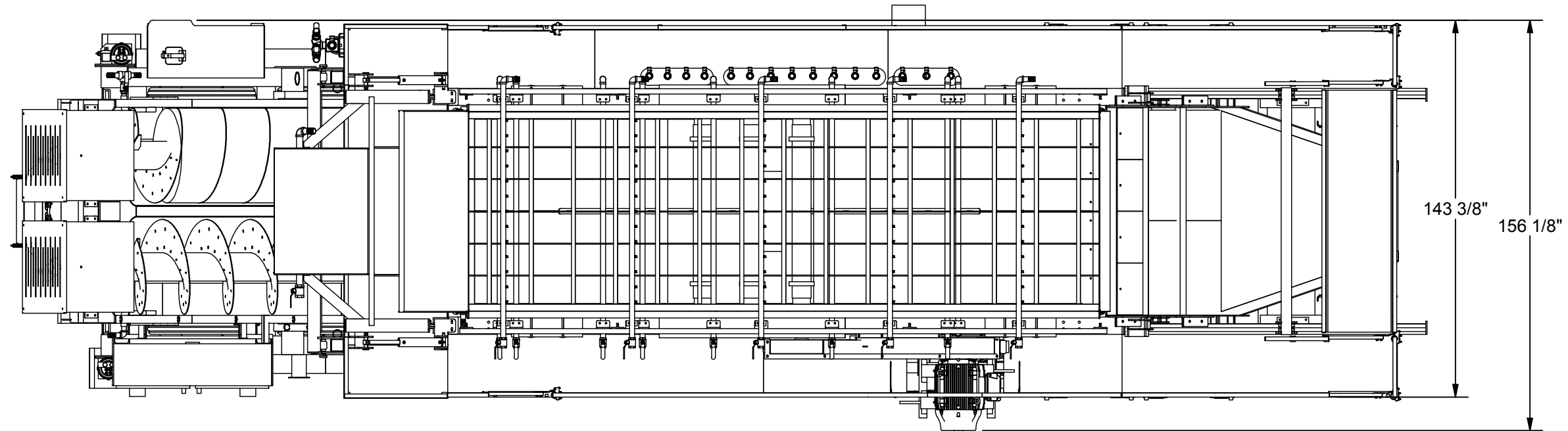

REAR HANDRAIL REMOVED  
WHEN SLURRY BOX FOLDED  
DOWN

MOTOR REMOVED FOR TRAVEL

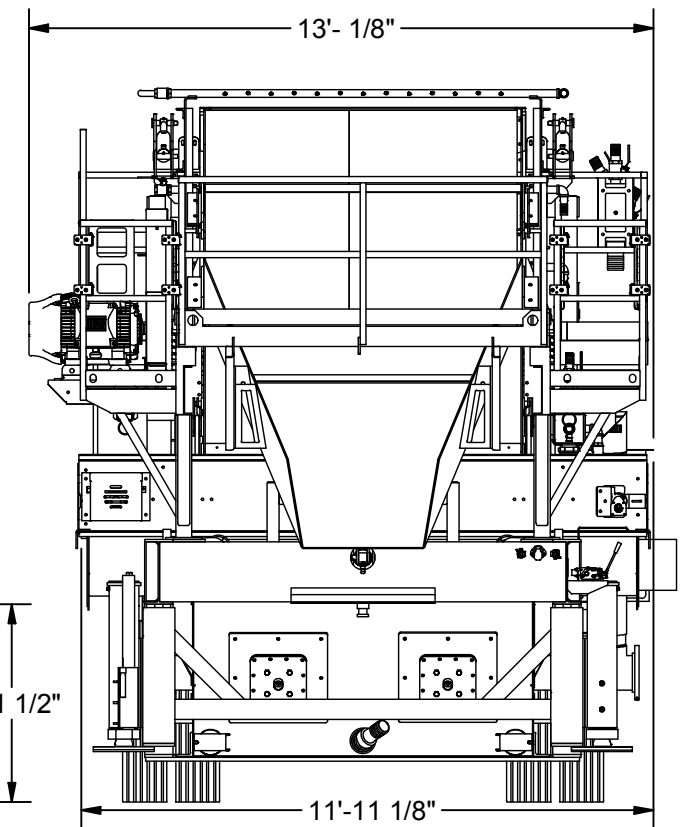
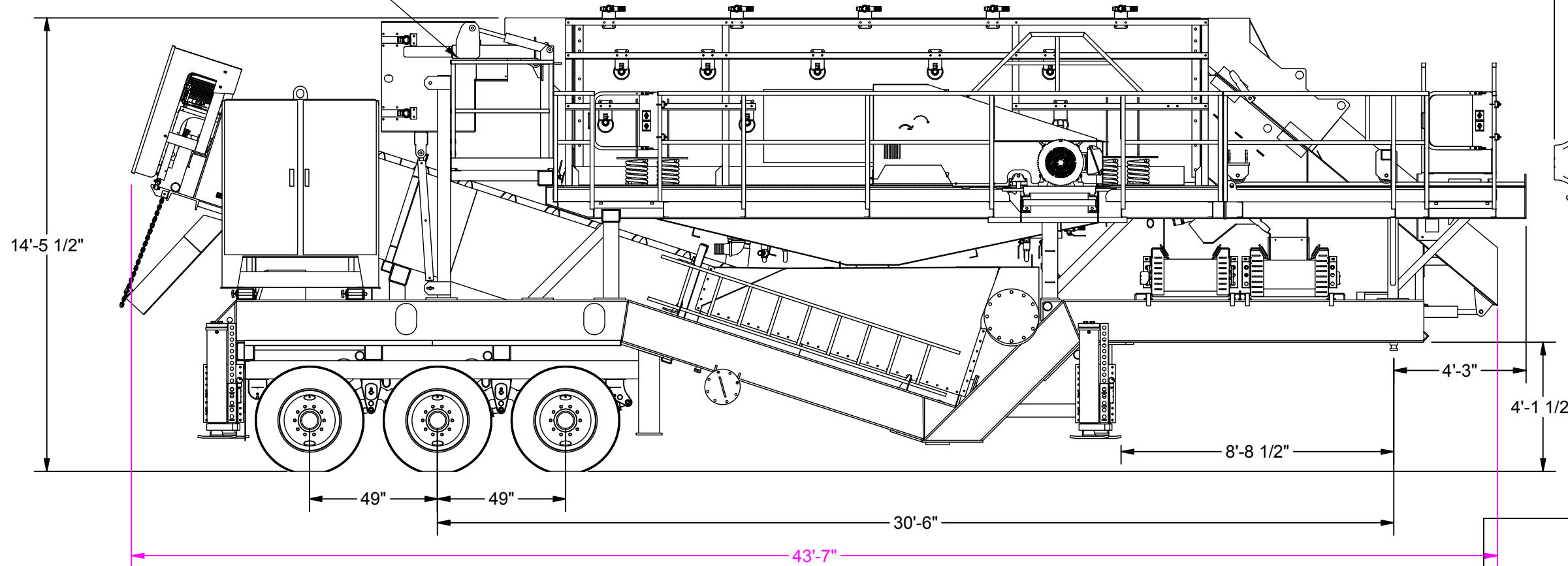

APPROX. AXLE WEIGHT  
50,000 LBS

APPROX. KINGPIN WEIGHT  
28,500 LBS

THIS DRAWING IS THE  
CONFIDENTIAL PROPERTY OF  
MASABA AND SHALL NOT BE  
DUPLICATED,  
COPIED, REPRODUCED OR  
DISCLOSED WITHOUT  
AUTHORIZED PERMISSION FROM  
MASABA.  
THIS DOCUMENT IS TO BE  
RETURNED UPON REQUEST.

**MASABA**

VERMILLION, SD USA 605-624-9555

DESCRIPTION <b>6x20 SCREEN W/ MASABA SCREW</b>		
DESIGNED BY <b>KLP</b>	WEIGHT N/A	SIZE <b>B</b>
DRAWN BY <b>KLP</b>	DATE 12/5/2017	SHEET 2 / 4
SCALE 1/4" = 1'	PART NUMBER 18149000	REV 000

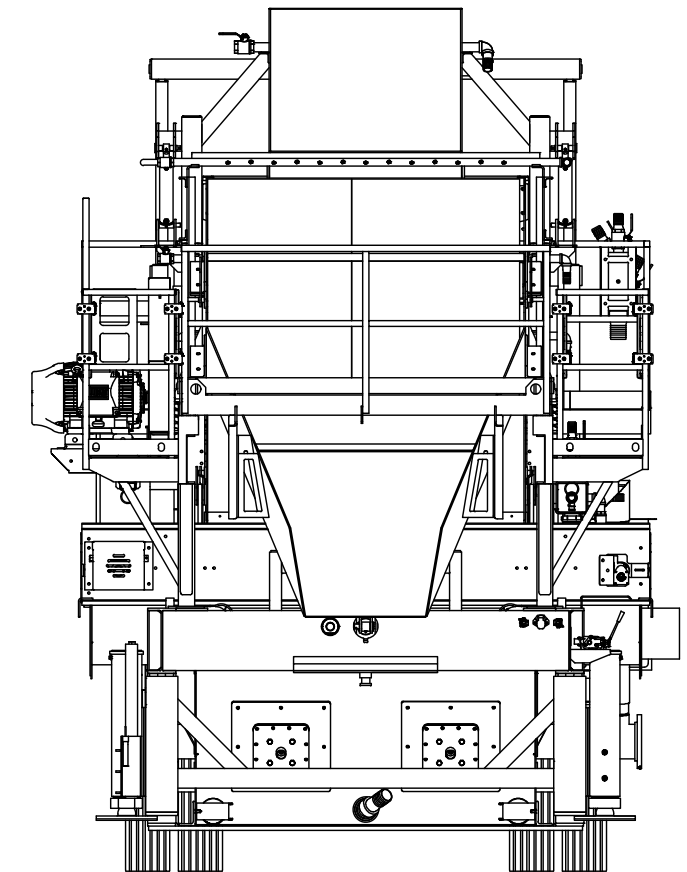
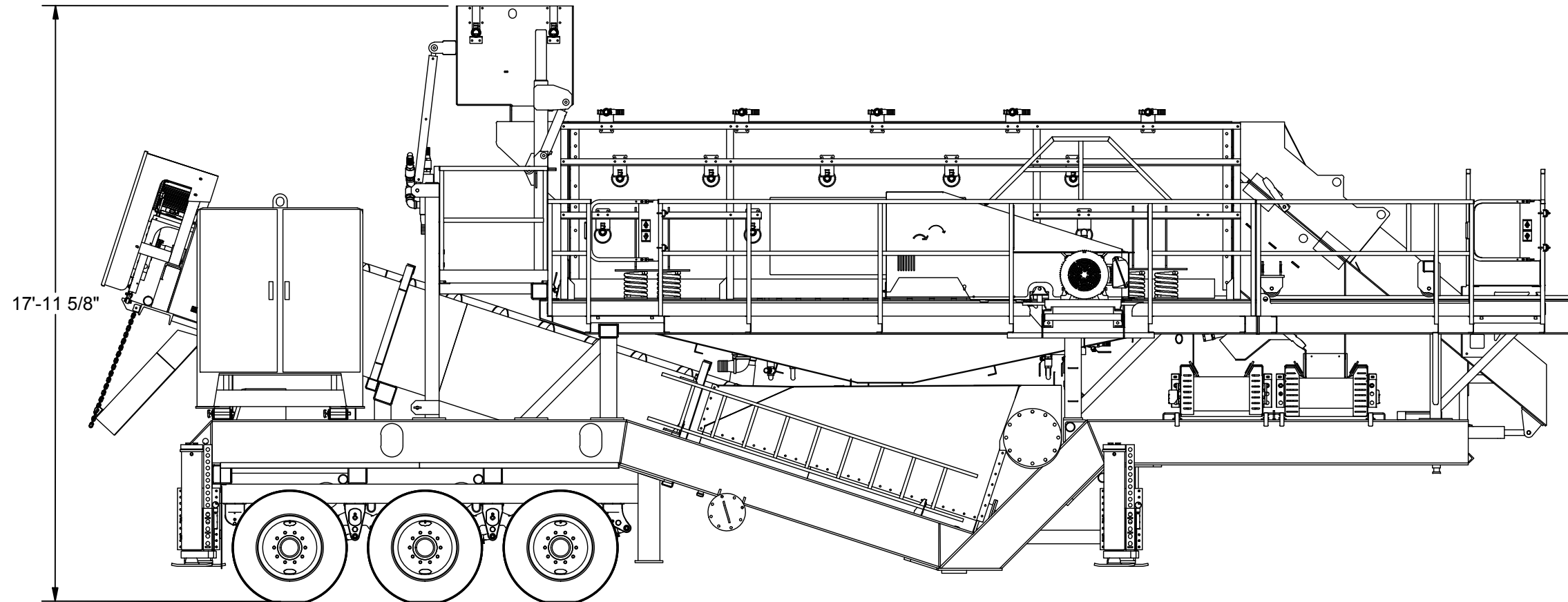
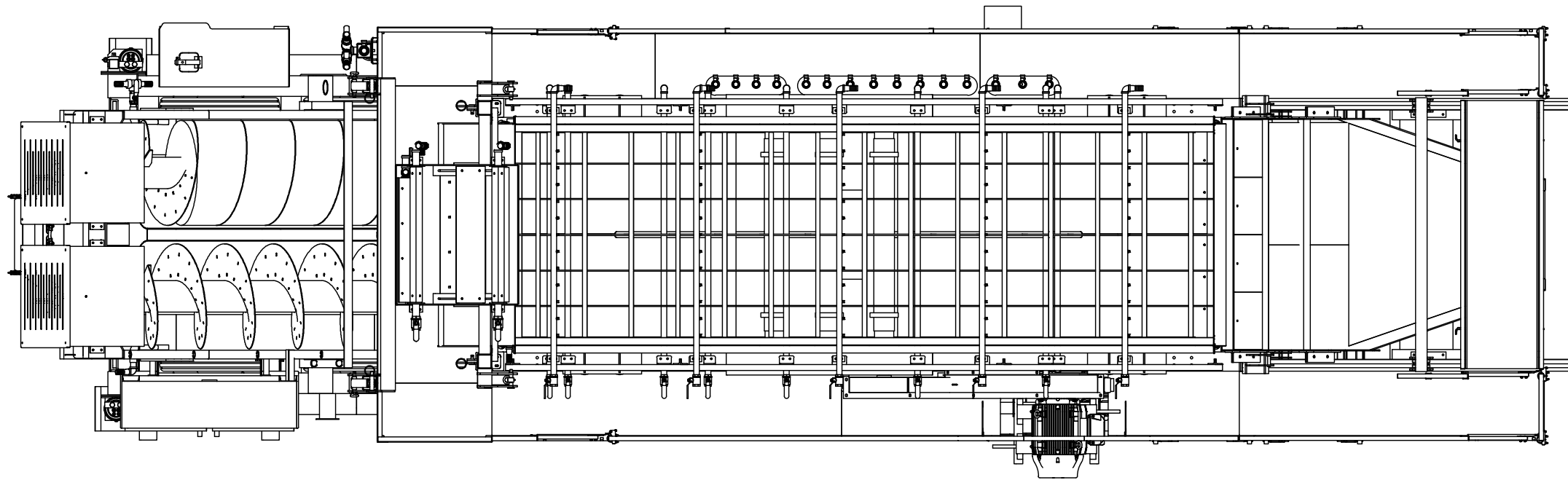

**MASABA**

VERMILLION, SD USA 605-624-9555

THIS DRAWING IS THE CONFIDENTIAL PROPERTY OF MASABA AND SHALL NOT BE DUPLICATED, COPIED, REPRODUCED OR DISCLOSED WITHOUT AUTHORIZED PERMISSION FROM MASABA. THIS DOCUMENT IS TO BE RETURNED UPON REQUEST.

DESCRIPTION <b>6x20 SCREEN W/ MASABA SCREW</b>		
DESIGNED BY <b>KLP</b>	WEIGHT <b>N/A</b>	SIZE <b>B</b>
DRAWN BY <b>KLP</b>	DATE <b>12/5/2017</b>	SHEET <b>3 / 4</b>
SCALE <b>1/4" = 1'</b>	PART NUMBER <b>18149000</b>	REV <b>000</b>



ROLLING CROSS CONVEYORS  
MOVE 33" IN EITHER DIRECTION

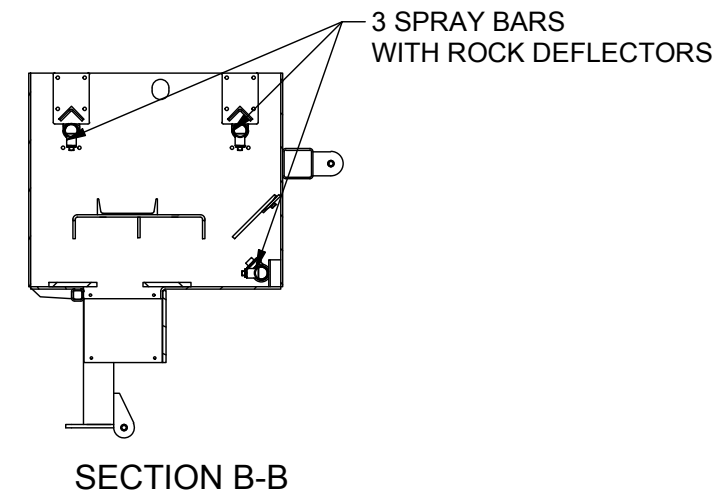
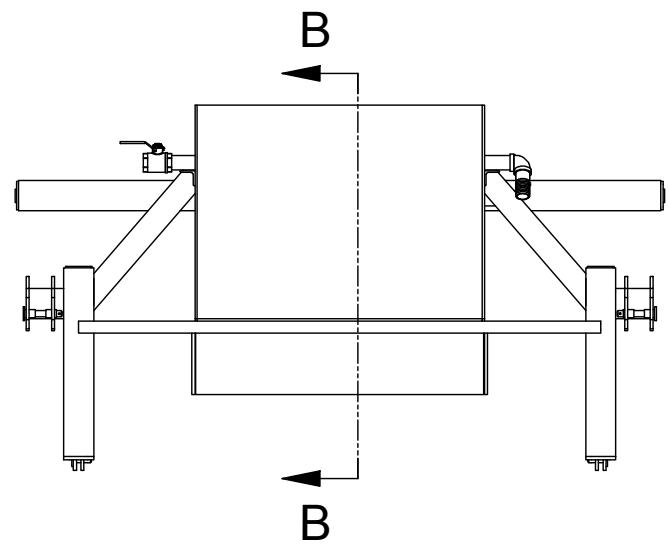
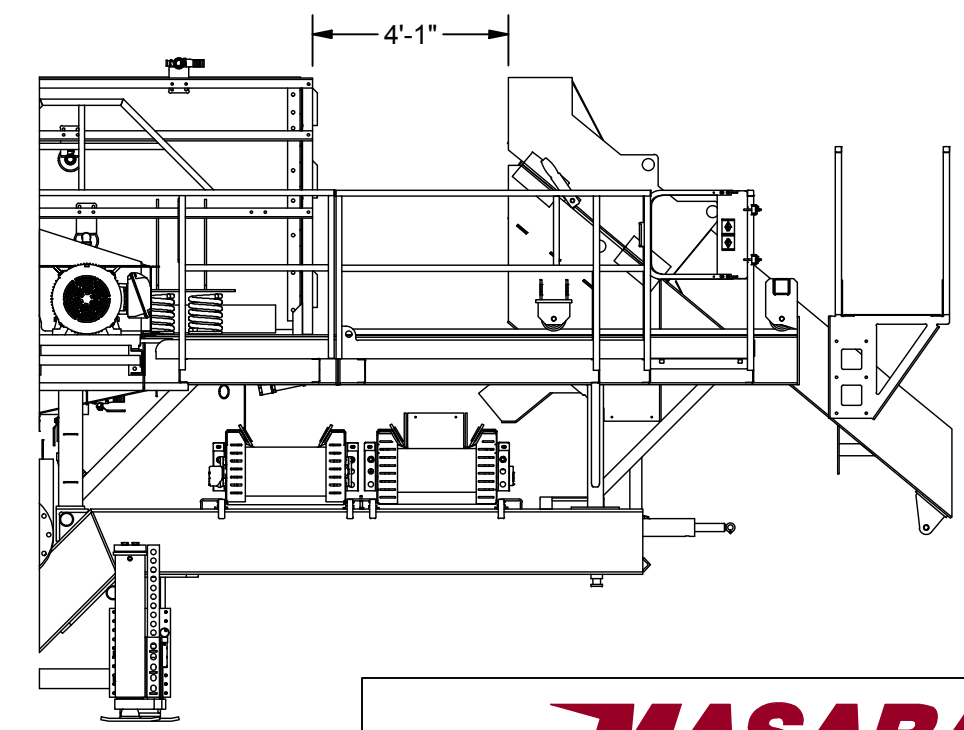
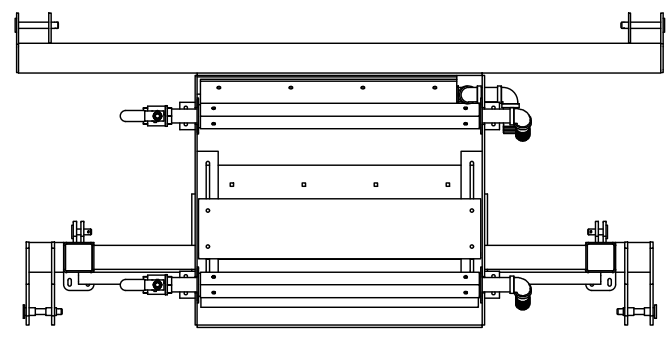
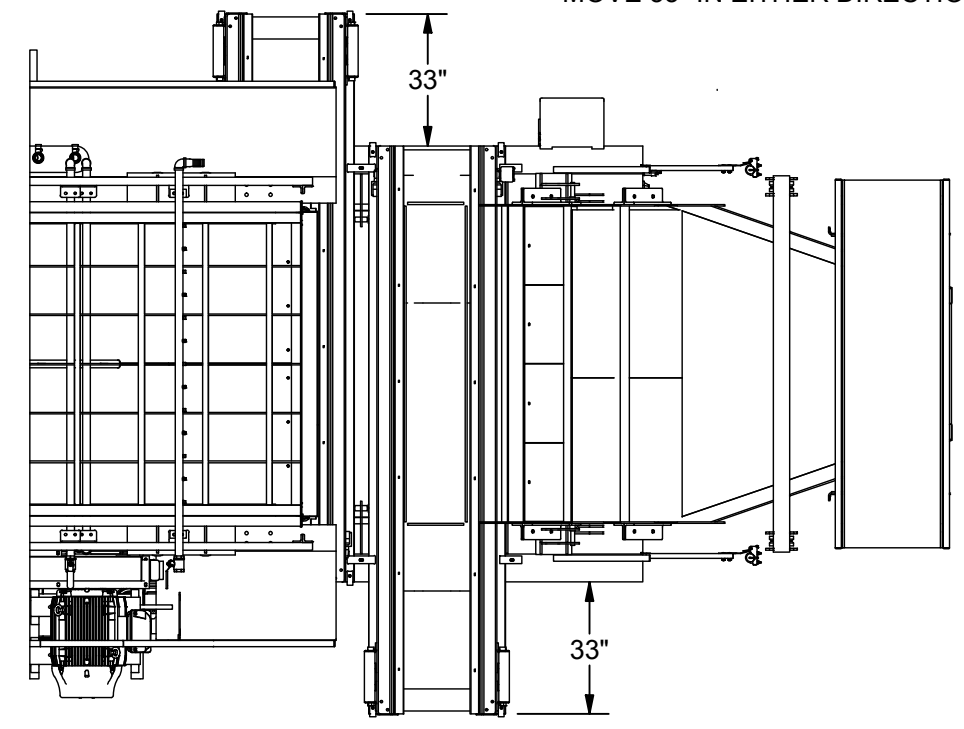
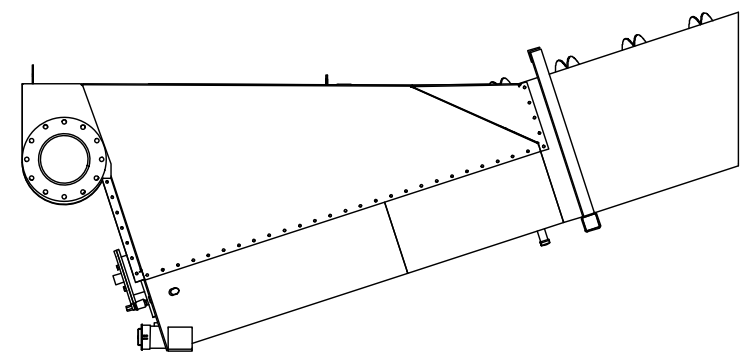
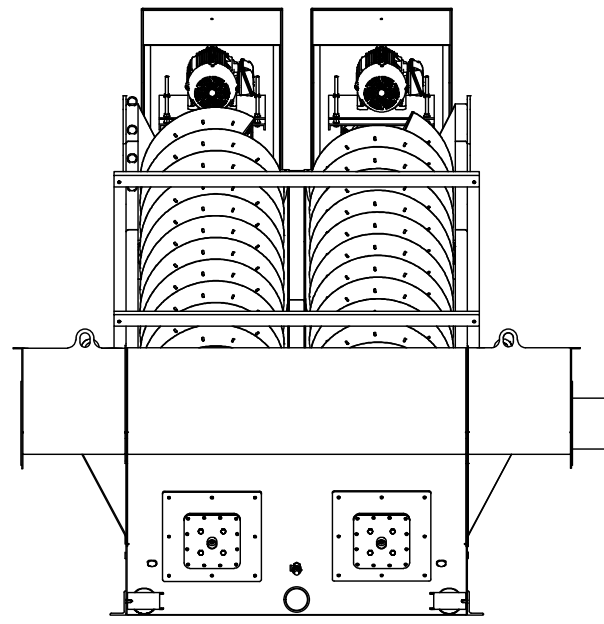

**MASABA**  
VERMILION, SD USA 605-624-9555

THIS DRAWING IS THE CONFIDENTIAL PROPERTY OF MASABA AND SHALL NOT BE DUPLICATED, COPIED, REPRODUCED OR DISCLOSED WITHOUT AUTHORIZED PERMISSION FROM MASABA. THIS DOCUMENT IS TO BE RETURNED UPON REQUEST.

DESCRIPTION <b>6x20 SCREEN W/ MASABA SCREW</b>		
DESIGNED BY <b>KLP</b>	WEIGHT N/A	SIZE <b>B</b>
DRAWN BY <b>KLP</b>	DATE 12/5/2017	SHEET <b>4 / 4</b>
SCALE 1/4" = 1'	PART NUMBER 18149000	REV 000