

PCS MK - 19233
6' DWS STRUCTURE, DISCHARGE CHUTE, UNDERPAN
SCALE 1/2" = 1'-0"

BILL OF MATERIAL			
ITEM	QTY	PCS MK	DESCRIPTION
1	1	19233-001	AGG. SPECIALISTS, STRUCTURE
2	2	19233-002	AGG. SPECIALIST, WALKWAY
3	2	19233-003-HR01	HANDRIAL, 01
4	4	19233-003-HR02	HANDRIAL, 02
5	2	19233-005	LADDER, AGG. SPECIALIST, 24" WIDE
6	1	19233-007	DISCHARGE CHUTE, AGG. SPECIALIST
7	1	19233-008	DWS UNDERPAN, AGG. SPECIALIST,
8	1	VD18 DWS MKII (MCLANAHAN)	DEWATERING SCREEN, VD18 MKII, MCLANAHAN
9	3	19233 GR	BAR GRATING, 168"X36"X1 1/2"
10	16		BOLT, HEX, 3/4" X 3.5" LG, UNC, A325
11	36		BOLT, HEX, 3/4" X 2.5" LG, UNC, A325
12	24		BOLT, HEX, 1/2" X 2.25" LG, UNC, A325
13	104		WASHER, FLAT, 3/4 - narrow - Type A
14	24		WASHER, BEVEL, 1/2"
15	8		WASHER, LOCK, 3/4"
16	44		WASHER, SQRT, 3/4"
17	24		WASHER, FLAT, 1/2 - wide - Type A
18	24		WASHER, SQRT, 1/2"
19	52		NUT, HEX, 3/4", UNC, A325
20	24		NUT, HEX, 1/2", UNC, A325

TITLE: 6' DWS STRUCTURE, DISCHARGE CHUTE, UNDERPAN

DRAWING INFO
DRAWN BY: ccoppinger
DATE: 7/3/2019
CHECKED: JH
DATE: 12/15/2019
SCALE: 1/2" = 1'-0"

WEIGHT: 24124.8 lbsmass
STATUS: RELEASED
DO NOT SCALE DRAWING
THIRD ANGLE PROJECTION
THIS PRINT IS THE PROPERTY OF NEPTUNE PROCESS, LLC AND IS SUBJECT TO THE TERMS AND CONDITIONS OF THE DRAWING. ANY REPRODUCTION OR DISTRIBUTION OF THIS DRAWING SHALL BE PROHIBITED WITHOUT WRITTEN AUTHORIZATION. (DO NOT SCALE OR COPY FOR INDIVIDUAL USE ONLY.)

HENDERSONVILLE
WORLD HEADQUARTERS
131 Popplewood Blvd
Hendersonville, TN 37075
Phone: 615-530-0896
www.neptuneprocess.com



REV: 1
SHT NO: 1 OF 2
DWG NO.: 19233

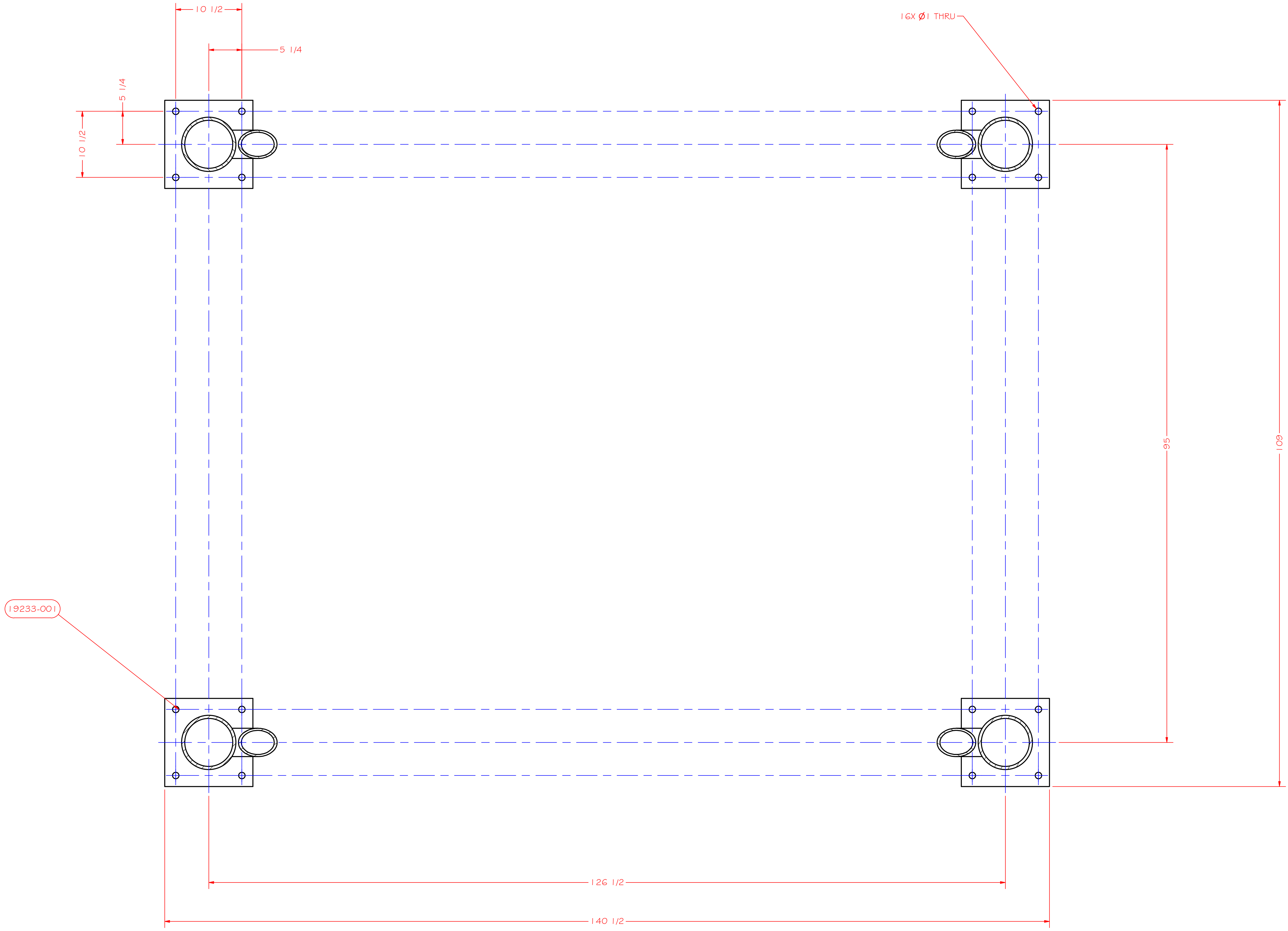

SECTION A-A
SCALE 1 1/2" = 1'-0"

19233-001



NEPTUNE PROCESS

HENDERSONVILLE
 WORLD HEADQUARTERS
 131 Popplewood Blvd
 Hendersonville, TN 37075
 Phone: 615-530-0896
 www.neptuneprocess.com

DRAWING INFO
 DRAWN BY: ccoppinger
 DATE: 7/3/2019
 CHECKED: JH
 DATE: 12/15/2019
 SCALE: 1 1/2" = 1'-0"

TOLERANCES: IMPERIAL
 (UNLESS OTHERWISE NOTED)
 DIMENSIONS: .005
 ASSEMBLY: +/- .18"
 X - REF. NOT APPLICABLE
 .XX +/- 0.02
 .XXX +/- 0.01
 +/- .132" NON-CUMULATIVE
 ANGULARITY +/- 1° 0'

TOLERANCES: METRIC
 (UNLESS OTHERWISE NOTED)
 DIMENSIONS: .15
 CLASS C COARSE
 TABLES 1, 2, & 3
 4001 UPWARDS +/- 6
 HOLE CENTERS:
 +/- 1 mm NON-CUMULATIVE

TITLE:
 6' DWS STRUCTURE, DISCHARGE CHUTE, UNDERPAN
 WEIGHT: 24124.8 lbsmass
 STATUS: RELEASED
 DO NOT SCALE DRAWING
 THIRD ANGLE PROJECTION
 THIS PRINT IS THE PROPERTY OF NEPTUNE PROCESS, LLC AND IS SUBJECT TO THE TERMS AND CONDITIONS OF THE PURCHASE ORDER. ANY REPRODUCTION OR DISTRIBUTION OF THIS DRAWING SHALL BE PROHIBITED WITHOUT WRITTEN AUTHORIZATION. (DO NOT SCALE OR COPY FOR INDIVIDUAL INDUSTRY USE.)

REV: 1
 SH1 NO: 2 OF 2
 DWG NO: 19233