

ISOMETRIC VIEW: WORKING MODE

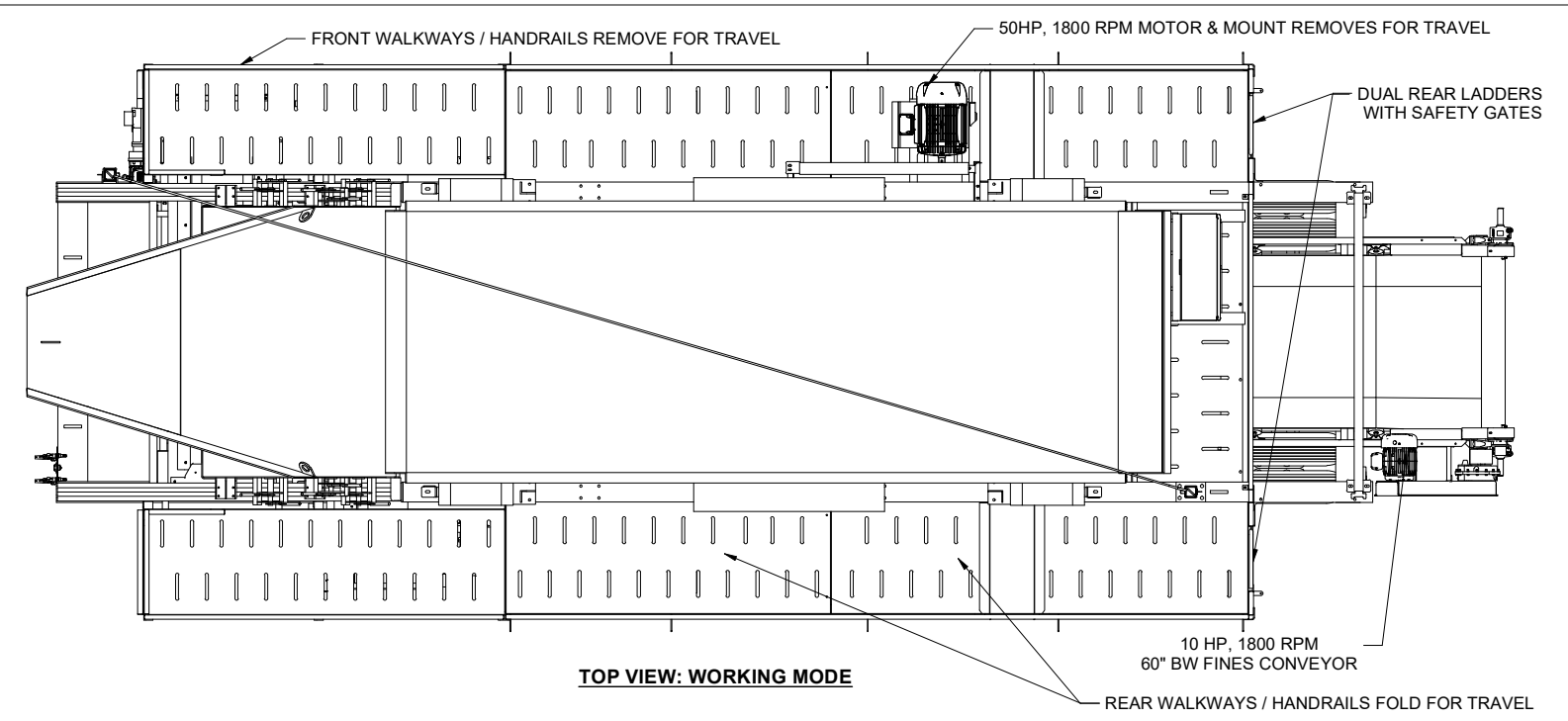

TOP VIEW: WORKING MODE

TRAVEL LENGTH: 40'-5 3/4" (FROM KING PIN)
 OVERALL LENGTH: 41'-9 1/8"
 TRAVEL WIDTH: 11'-8 15/16"
 TRAVEL HEIGHT: 14'-5 5/8"
 SHIPPING WEIGHT: APPROX 58,500 LB GROSS
 KINGPIN WEIGHT: 24,360 LB
 WEIGHT ON TANDEM: 34,140 LB

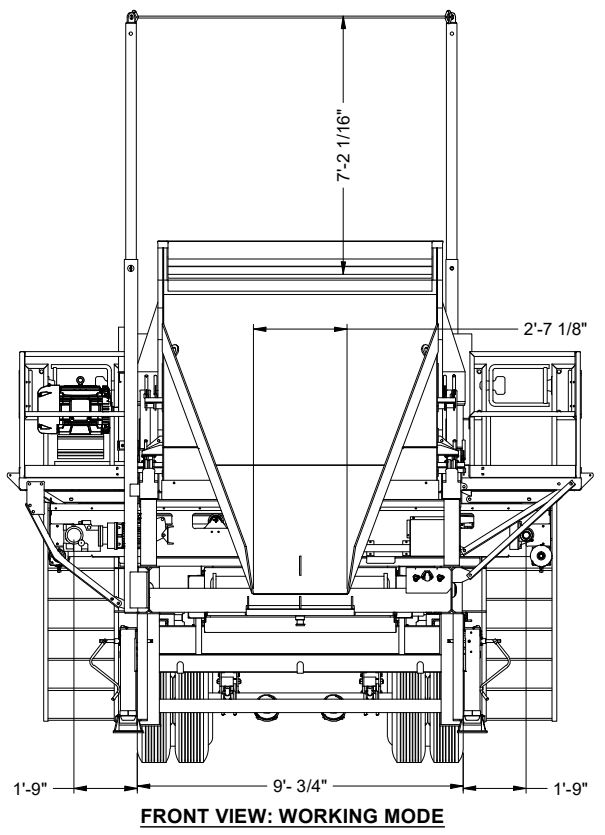

FRONT VIEW: WORKING MODE

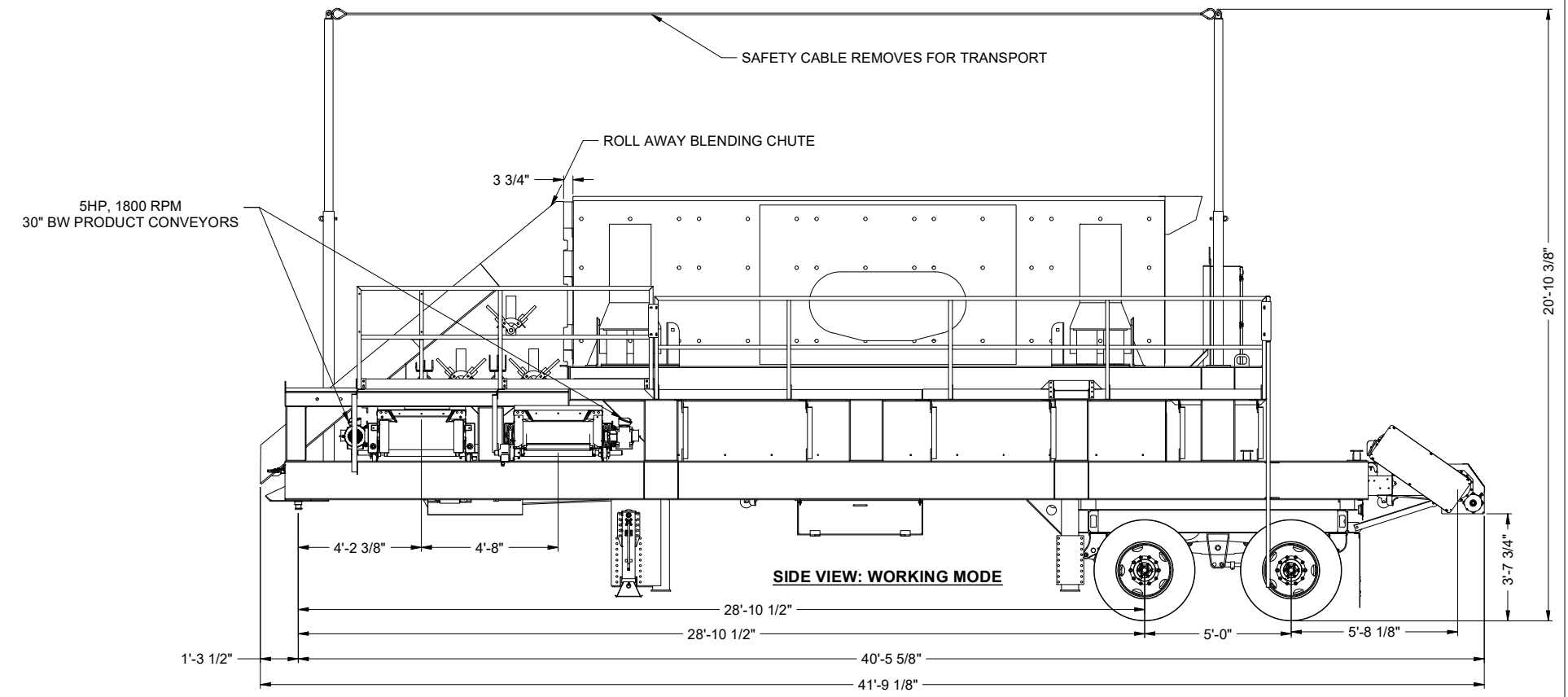

SIDE VIEW: WORKING MODE



201 E. Quindaro Blvd., Kansas City, Kansas 66115
 PHONE: 913-342-2240 FAX: 913-342-2237

DESIGNED BY:	SRODRIQUEZ	PORTABLE 7203 CACSTM
DRAWN BY:	SRODRIQUEZ	SALES DRAWING
SCALE:	3/16"=1'-0"	AMS
DATE:	3/29/2022	
FILE NAME:	31282-SALES	WEIGHT: 58,500 lbs
		SHEET 1/2

REV	DESCRIPTION	DATE
A	UPDATED DIMENSIONS	8/31/2022
REVISION HISTORY		

THIS DOCUMENT AND ALL INFORMATION CONTAINED HEREIN IS PROPRIETARY AND IS THE EXCLUSIVE PROPERTY OF PEERLESS CONVEYOR AND MANUFACTURING CO. DISCLOSED WITH THE UNDERSTANDING THAT IT WILL BE RETAINED IN CONFIDENCE. NEITHER RECEIPT NOR POSSESSION CONFERS OR TRANSFERS ANY RIGHTS TO REPRODUCE, USE OR DISCLOSE IN WHOLE OR IN PART, DATA CONTAINED HEREIN FOR ANY PURPOSE, WITHOUT THE PRIOR WRITTEN PERMISSION OF PEERLESS CONVEYOR AND MANUFACTURING CO.

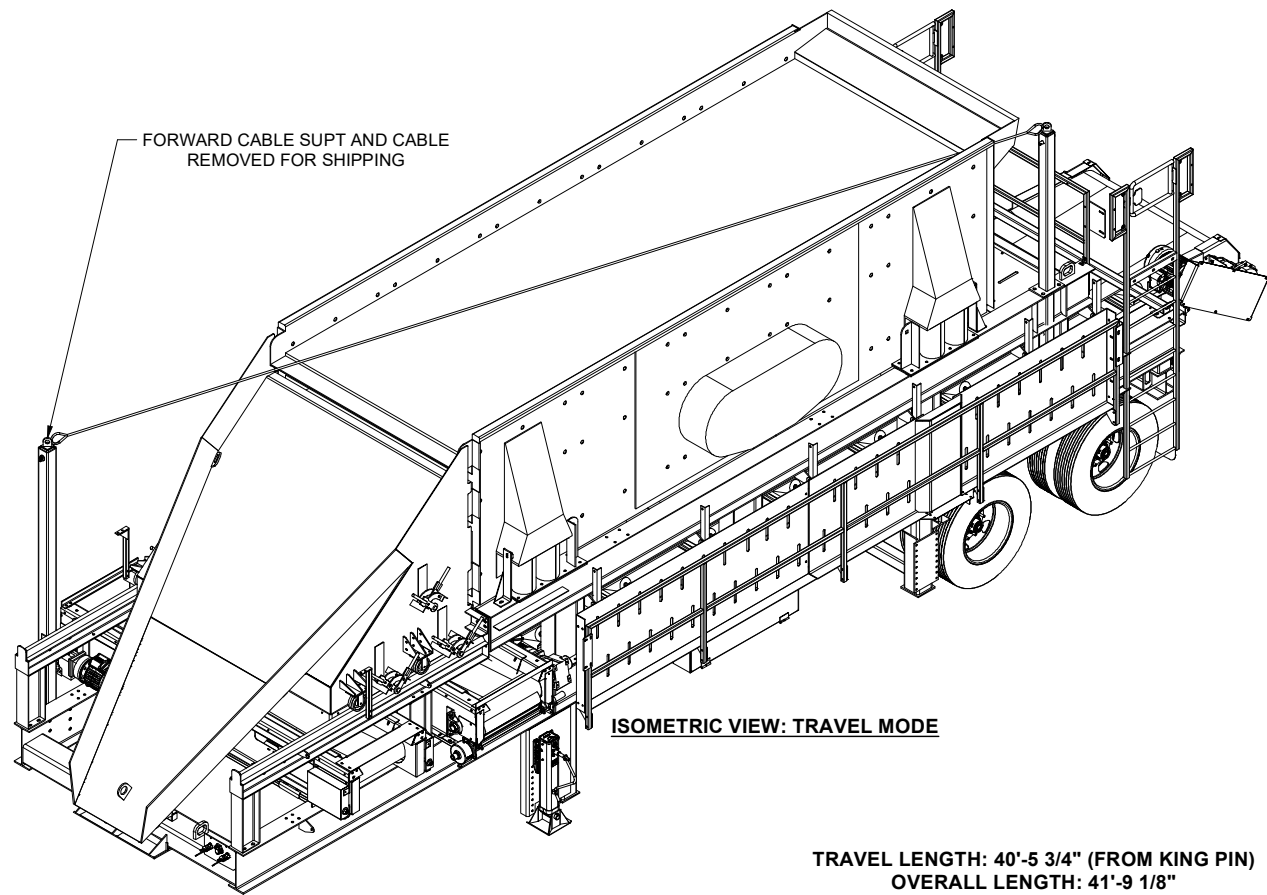

ISOMETRIC VIEW: TRAVEL MODE

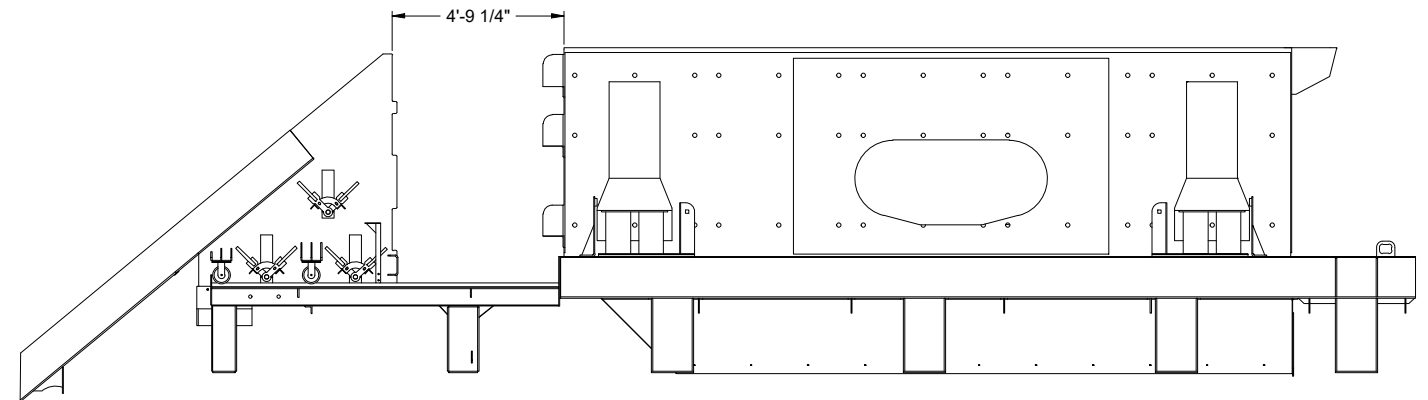

SIDE VIEW: ROLL AWAY CHUTE OPEN

TRAVEL LENGTH: 40'-5 3/4" (FROM KING PIN)
 OVERALL LENGTH: 41'-9 1/8"
 TRAVEL WIDTH: 11'-8 15/16"
 TRAVEL HEIGHT: 14'-5 5/8"

SHIPPING WEIGHT: APPROX 58,500 LB GROSS
 KINGPIN WEIGHT: 24,360 LB
 WEIGHT ON TANDEM: 34,140 LB

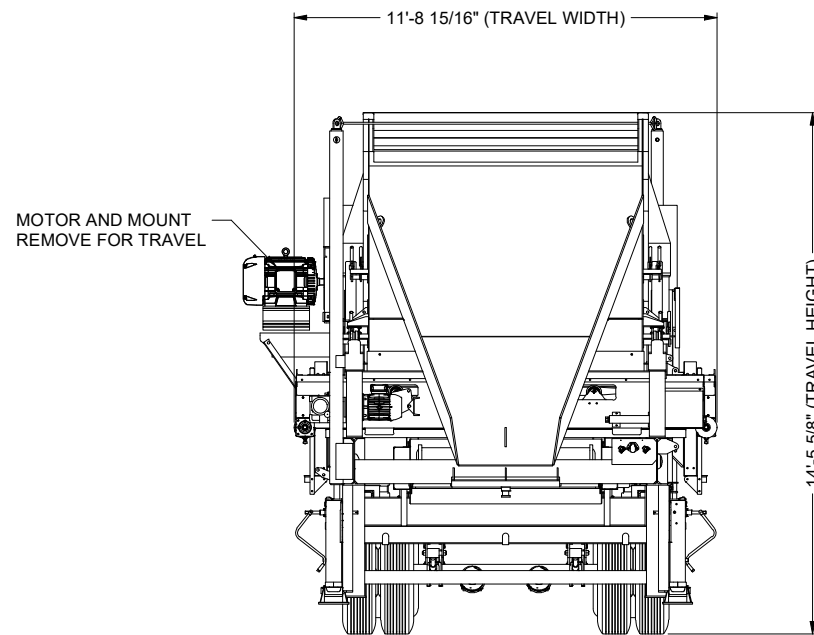

FRONT VIEW: TRAVEL MODE

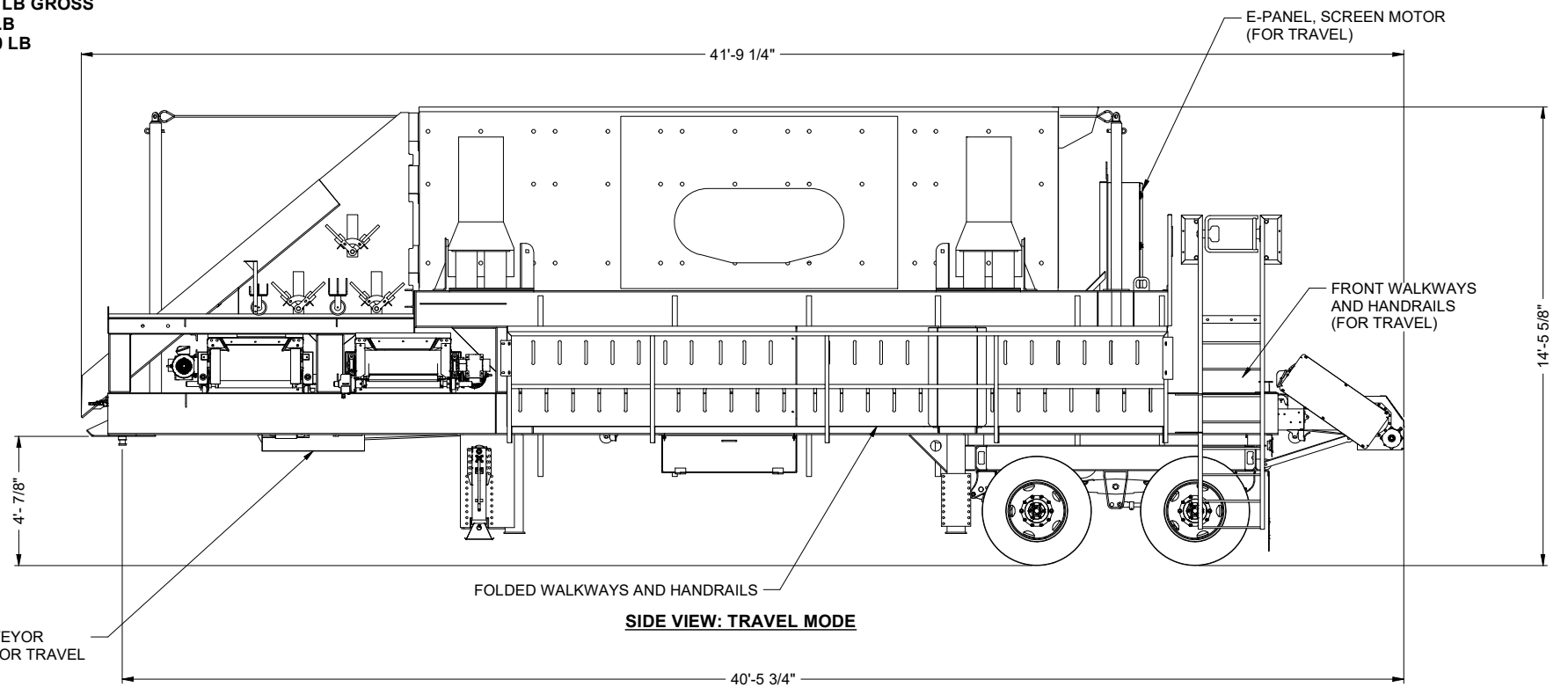

SIDE VIEW: TRAVEL MODE

UNDER SCREEN CONVEYOR
 GUARD IS REMOVED FOR TRAVEL



201 E. Quindaro Blvd., Kansas City, Kansas 66115
 PHONE: 913-342-2240 FAX: 913-342-2237

DESIGNED BY: SRODRIQUEZ PORTABLE 7203 CACSTM

DRAWN BY: SRODRIQUEZ SALES DRAWING

SCALE: 3/16"=1'-0" AMS

DATE: 3/29/2022

FILE NAME: 31282-SALES

WEIGHT: 58,500 lbs

SHEET
2/2

THIS DOCUMENT AND ALL INFORMATION CONTAINED HEREIN IS PROPRIETARY AND IS THE EXCLUSIVE PROPERTY OF PEERLESS CONVEYOR AND MANUFACTURING CO. DISCLOSED WITH THE UNDERSTANDING THAT IT WILL BE RETAINED IN CONFIDENCE. NEITHER RECEIPT NOR POSSESSION CONFERS OR TRANSFERS ANY RIGHTS TO REPRODUCE, USE OR DISCLOSE IN WHOLE OR IN PART, DATA CONTAINED HEREIN FOR ANY PURPOSE, WITHOUT THE PRIOR WRITTEN PERMISSION OF PEERLESS CONVEYOR AND MANUFACTURING CO.

A	UPDATED DIMENSIONS	8/31/2022
REV	DESCRIPTION	DATE
REVISION HISTORY		