

CERTIFICATION		
Aggregate Machinery Specialist		
CUSTOMER ORDER NUMBER: 16718		
MCLANAHAN SERIAL NUMBER: 20229055		
	DATE	BY
PRELIMINARY PRINT SENT		
APPROVAL DRAWING SENT	11/4/22	IRS
CERTIFIED DIMENSIONAL ACCURACY		
FINAL CERTIFIED DRAWING		

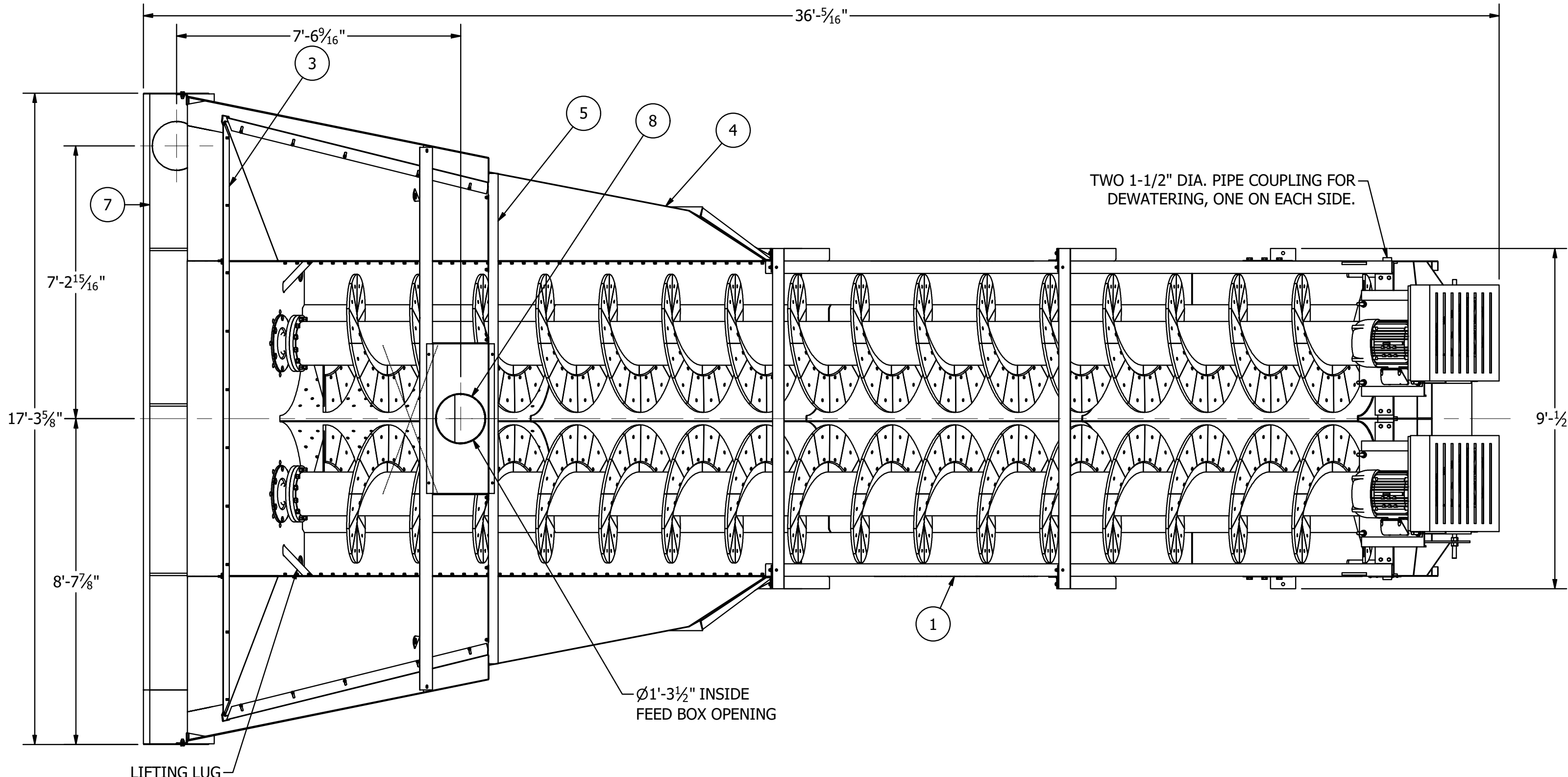

PARTS LIST						
Ships Loose	Item	Part Number	Description	Qty	Wt	
	1	US35000361	TUB ASSEMBLY, CONDOR 44" DIA. X 32' DSFM WASHER, CONVEYORS W/ WHITE IRON SHOES, 25 HP MOTORS, 100% DRIVE	1	26614	
*	2	A18484	CHUTE, DISCHARGE, 44 IN DF WASHER	1	283	
*		294740820	CAPSCREW, HEX HEAD, 0.5X1.25 IN, NC, GRADE 5, ZINC PLATED	4		
*		296507080	NUT, HEX, 0.5 IN, NC, GRADE 5, ZINC PLATED	4		
*		296700800	WASHER, LOCK, 0.5 IN, ZINC PLATED	4		
*	3	D05929	END WEIR	1	58	
*		294740820	CAPSCREW, HEX HEAD, 0.5X1.25 IN, NC, GRADE 5, ZINC PLATED	10		
*		296700800	WASHER, LOCK, 0.5 IN, ZINC PLATED	10		
*		296507080	NUT, HEX, 0.5 IN, NC, GRADE 5, ZINC PLATED	10		
*	4	A03303	SIDE FLARE ASSEMBLY, 44 & 54 FM WASHER	1	1502	
128*		294740820	CAPSCREW, HEX HEAD, 0.5X1.25 IN, NC, GRADE 5, ZINC PLATED	138		
128*		296700800	WASHER, LOCK, 0.5 IN, ZINC PLATED	138		
128*		296507080	NUT, HEX, 0.5 IN, NC, GRADE 5, ZINC PLATED	138		
*		B20758	GASKET KIT, SIDE FLARE ASSEMBLY	1		
*		D07562	WEIR, SIDE, 44 IN, 54 IN, AND 66 IN FM WASHER	2		
*		D16062	CORNER WEIR, FORMED, FM WASHER	2		
*	5	A15116	FEED BOX ASSEMBLY	1	383	
*		294740820	CAPSCREW, HEX HEAD, 0.5X1.25 IN, NC, GRADE 5, ZINC PLATED	6		
*		296700800	WASHER, LOCK, 0.5 IN, ZINC PLATED	6		
*		296507080	NUT, HEX, 0.5 IN, NC, GRADE 5, ZINC PLATED	6		
*	6	B22078	SUPPORT, WASHER, 66 IN SF & DF AND 44 IN DF WASHER	1	491	
*		294741632	CAPSCREW, HEX HEAD, 1" X 2", NC, GRADE 5, ZINC PLATED	12		
*		296701600	WASHER, LOCK, 1", ZINC PLATED	12		
*		296507160	NUT, HEX, 1", NC, GRADE 5, ZINC PLATED	12		
*	7	A23030	OVERFLOW FLUME	1	722	
*		294741028	CAPSCREW, HEX HEAD, 0.625X1.75 IN, NC, GRADE 5, ZINC PLATED	4		
*		296701000	WASHER, LOCK, 0.625 IN, ZINC PLATED	4		
*		296507100	NUT, HEX, 0.625 IN, NC, GRADE 5, ZINC PLATED	4		
8		B02860	INLET COVER, 44, 48, & 54 IN DF WASHER	1	172	
9		D43757	DECAL, CONDOR LOGO, MEDIUM	2	7	
10		D16639	DECAL, 17.625" X 52.00" EIW LOGO	2	1	
11		D03180	NAME PLATE	1	1	
12		297212003	SCREW, DRIVE, TYPE U, #12 X 1/2 IN ROUND HEAD DRIVE SCREW, ZINC	2	0	
13		D38050	DECAL, KIT, EIW WASHERS	1	0	
14		PIDP20229055	IDENTIFICATION PLATE, PROJECT ID 20229055	1	1	
15		US50800152	DRIVE SCREW, #14-9 X 0.75 IN, TYPE U, ROUND HEAD, 18-8 SST	2	0	

* SHIPS LOOSE

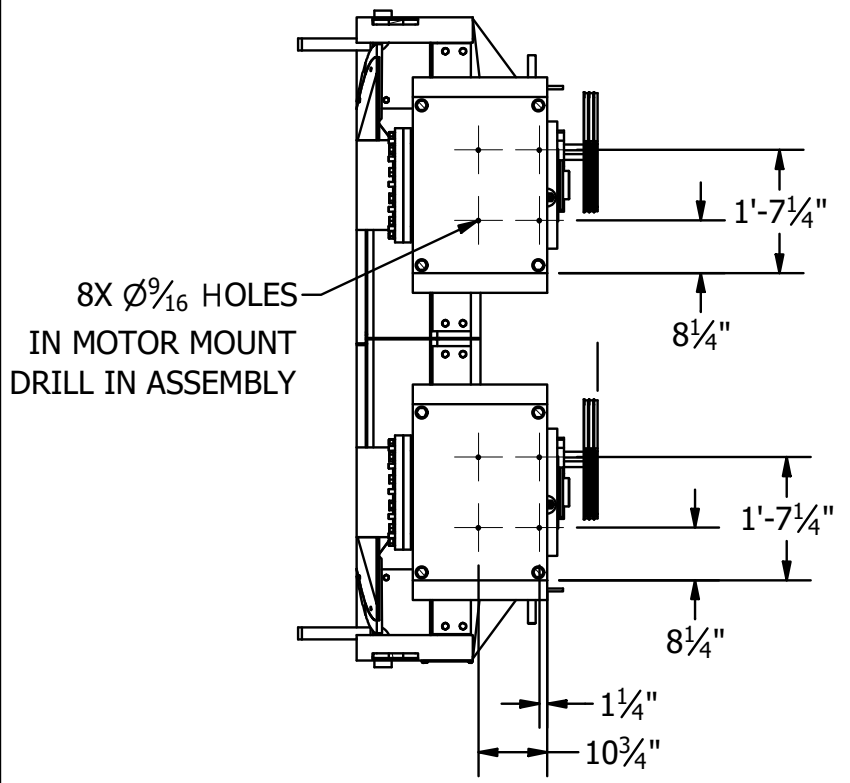
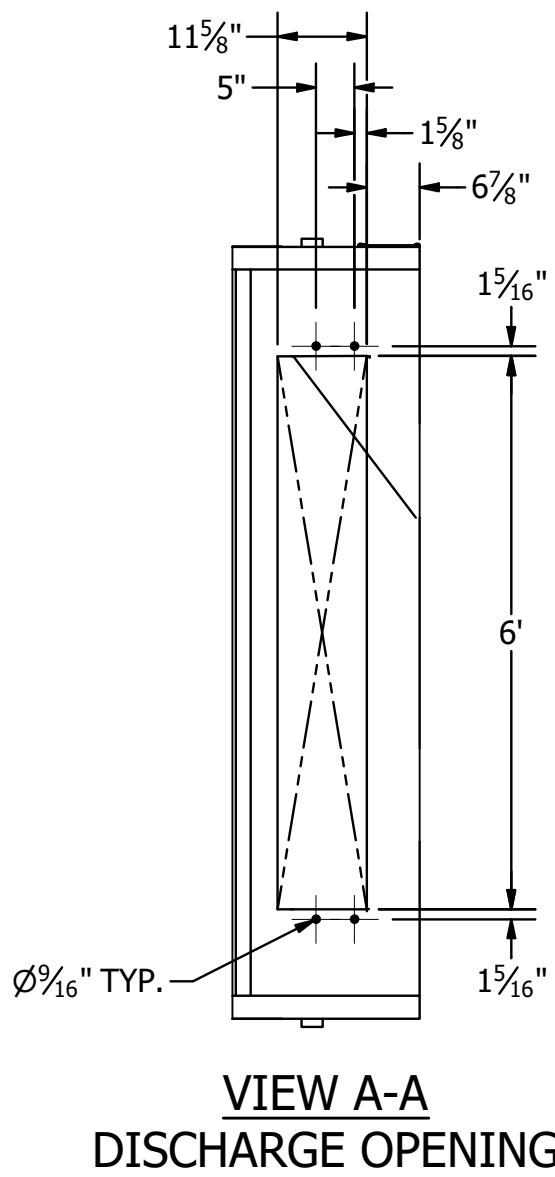
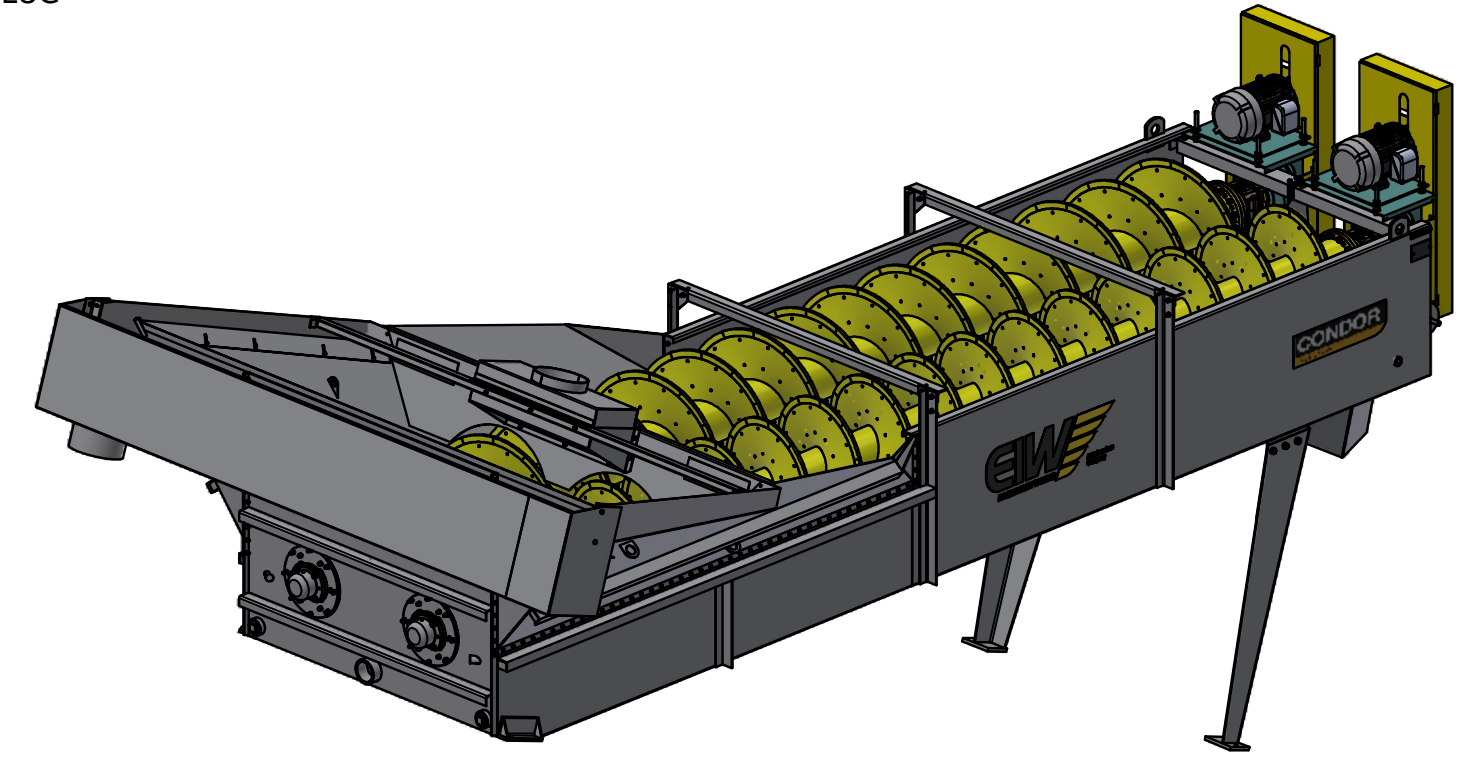

DRIVE MOTORS FOR 100% (17 RPM) CONVEYOR SHAFT SPEED. 25 HP, 1800 RPM, DESIGN B, 1.15 SERVICE FACTOR, TEFC, 460/3/60 POWER.

DRIVE SUPPLIED BY MCLANAHAN
INSTALLED BY MCLANAHAN

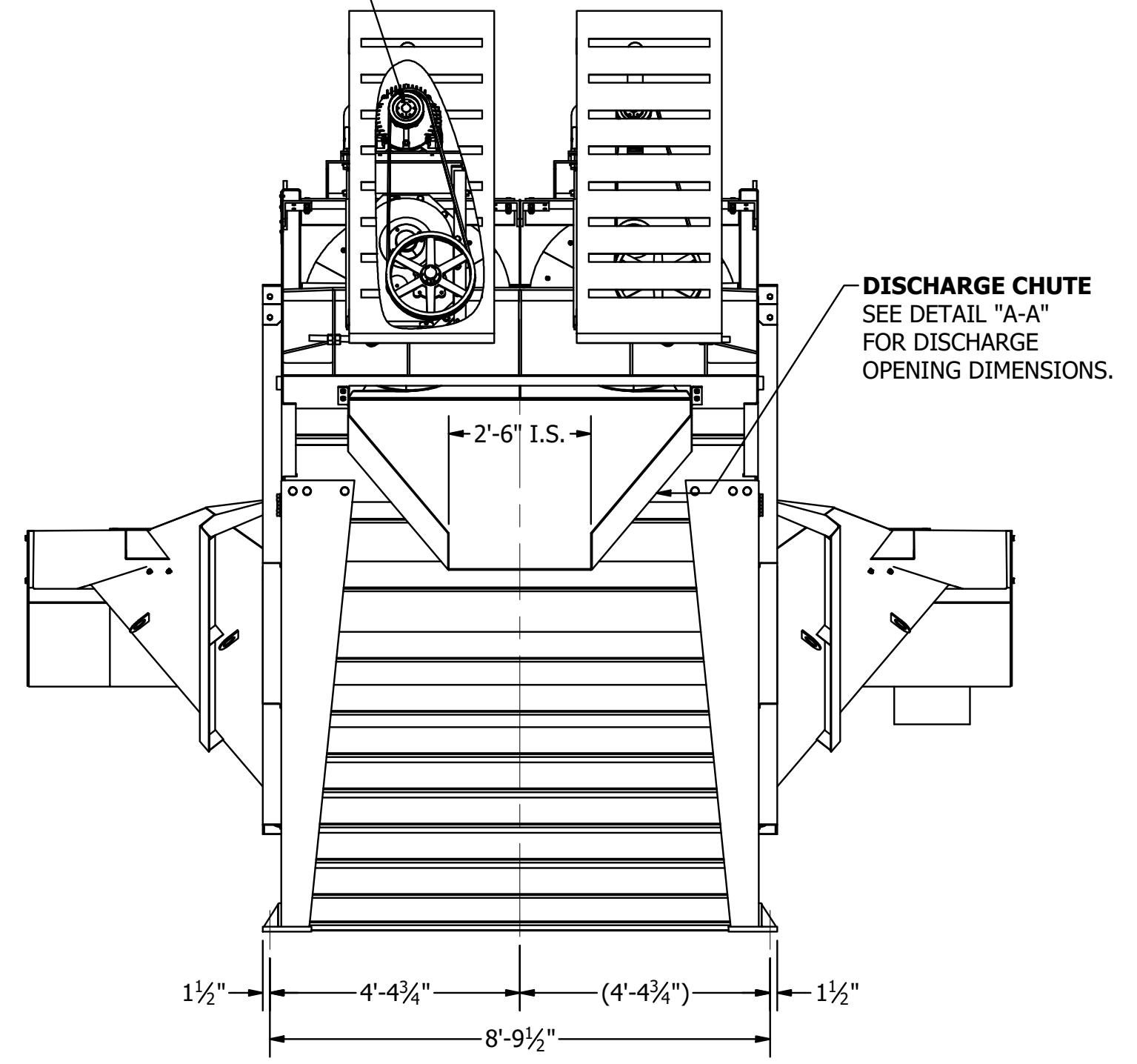
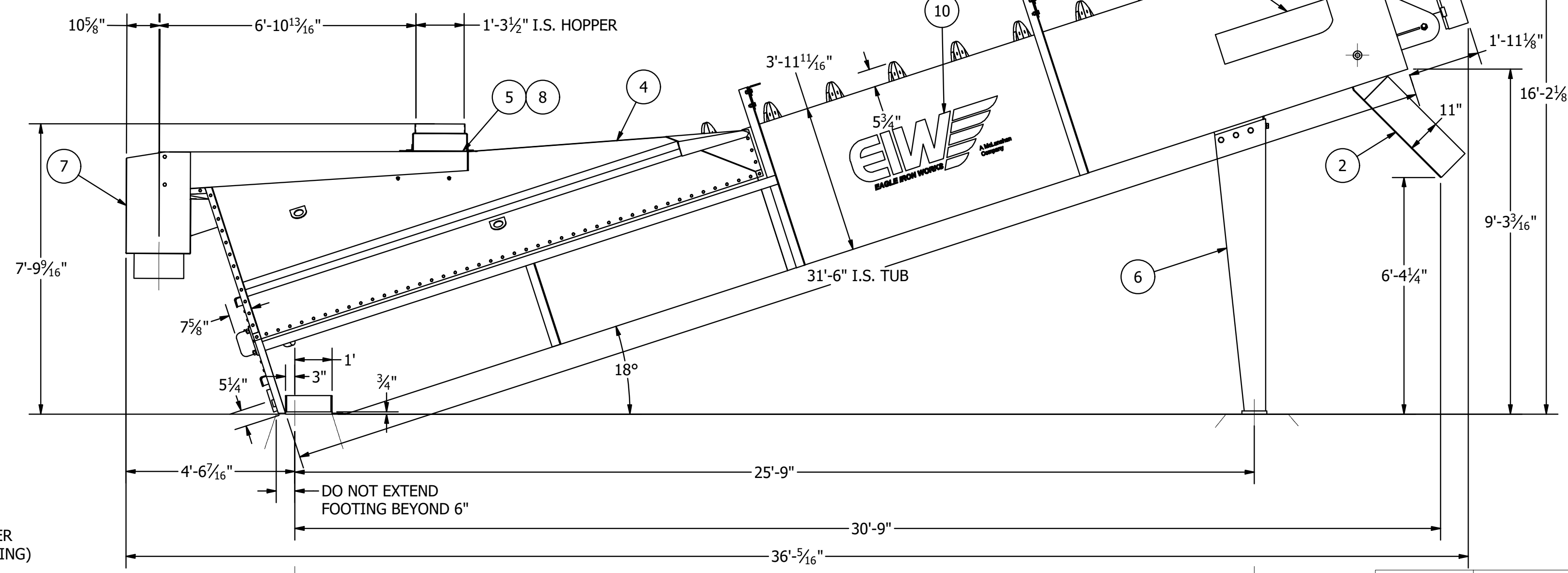
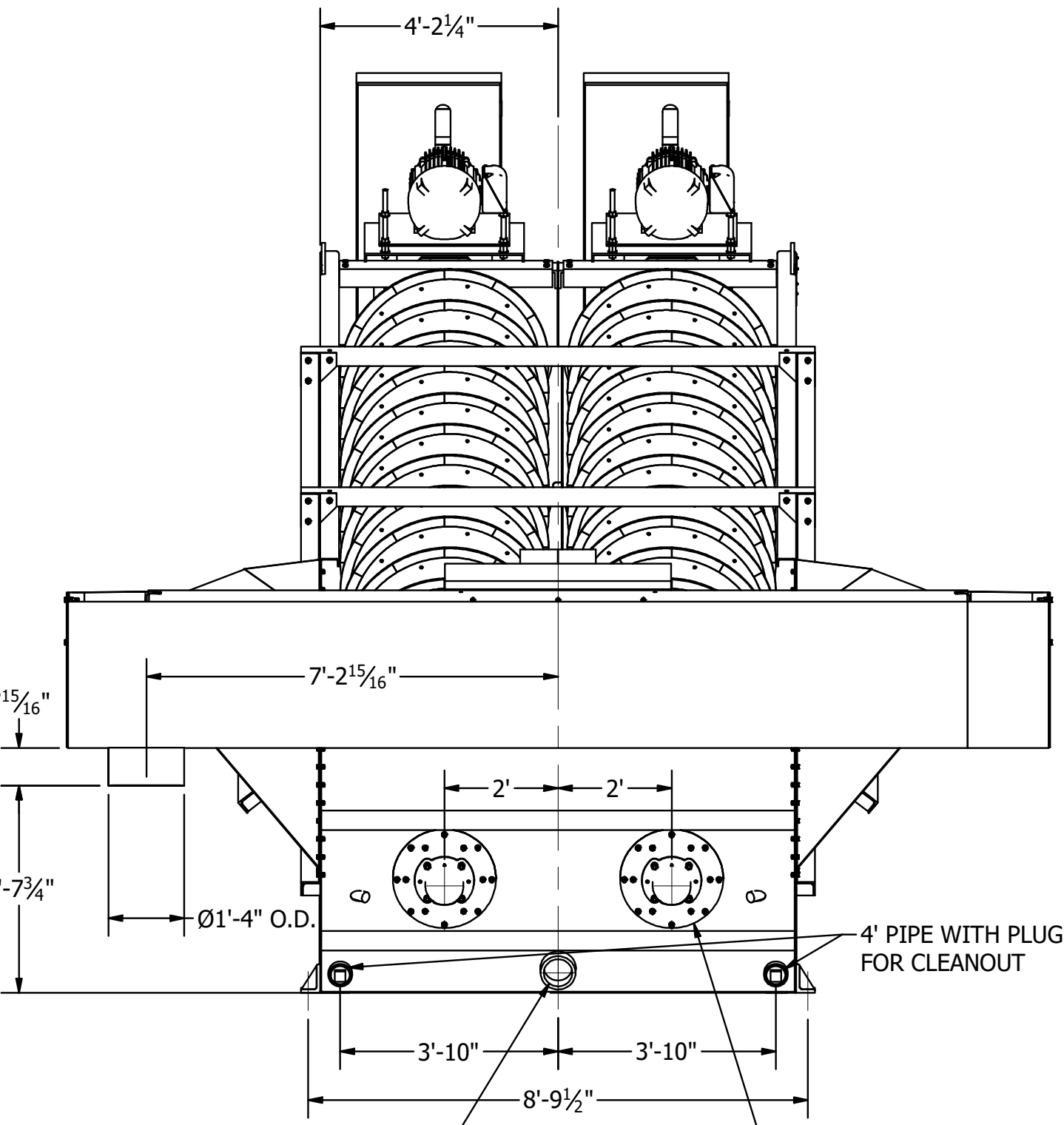

NOTES:
ALL ANCHOR BOLTS 7/8" DIA.
MACHINE WEIGHT = 30,030 LB.
LOADED WEIGHT = 122,500 LB.

CAUTION:
DO NOT RESTRICT MATERIAL
DISCHARGE OPENING. POSSIBLE
DAMAGE TO MACHINE MAY RESULT.

FOOTING REACTION
46,500 LBS



WEIGHT: 30,030 LB	SHEET NUMBER: 1 OF 1	SCALE: 1:30	PART NUMBER: DSFMC44X3220229055
UNLESS OTHERWISE NOTED, TOLERANCES ON DIMENSIONS ARE: Ø .001 IN. FINISHES: PROFILES/SAW .25 IN FABRICATION .015 IN ANGLES .5° SURFACE 1/32	DESIGNER: MCLANAHAN CORPORATION	DRAWN BY: IRS	DESCRIPTION: INSTALL, 44" X 32' DSFM CONDOR, OVERFLOW FLUMES, DISCHARGE CHUTES, WASHER SUPPORTS, 100% DRIVE, CONVEYORS W/ WHITE IRON WEAR SHOES
REFERENCES: US35000380	CHECKED BY: DLE	APPROVED BY: DLE	DATE: 10/28/2022
	THIRD ANGLE PROJECTION	CUSTOMER DRAWING	SHEET SIZE: D
			DRAWING NUMBER: US35000443
			REVISION: